

Smartfloor Revolution installation & instruction

General view of the Smartfloor Revolution

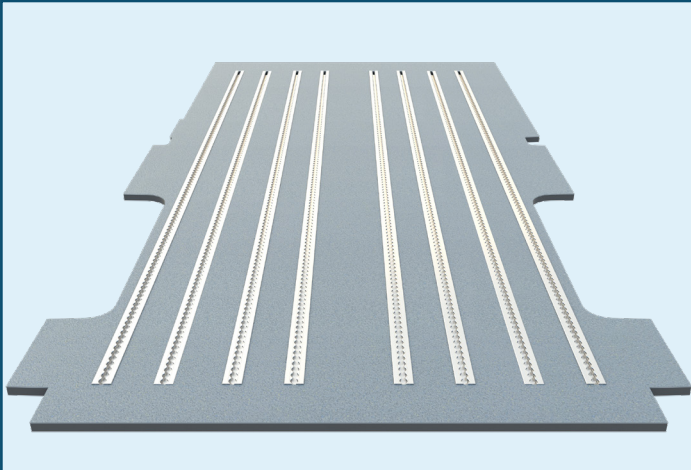

Light weight / **Composite floor**

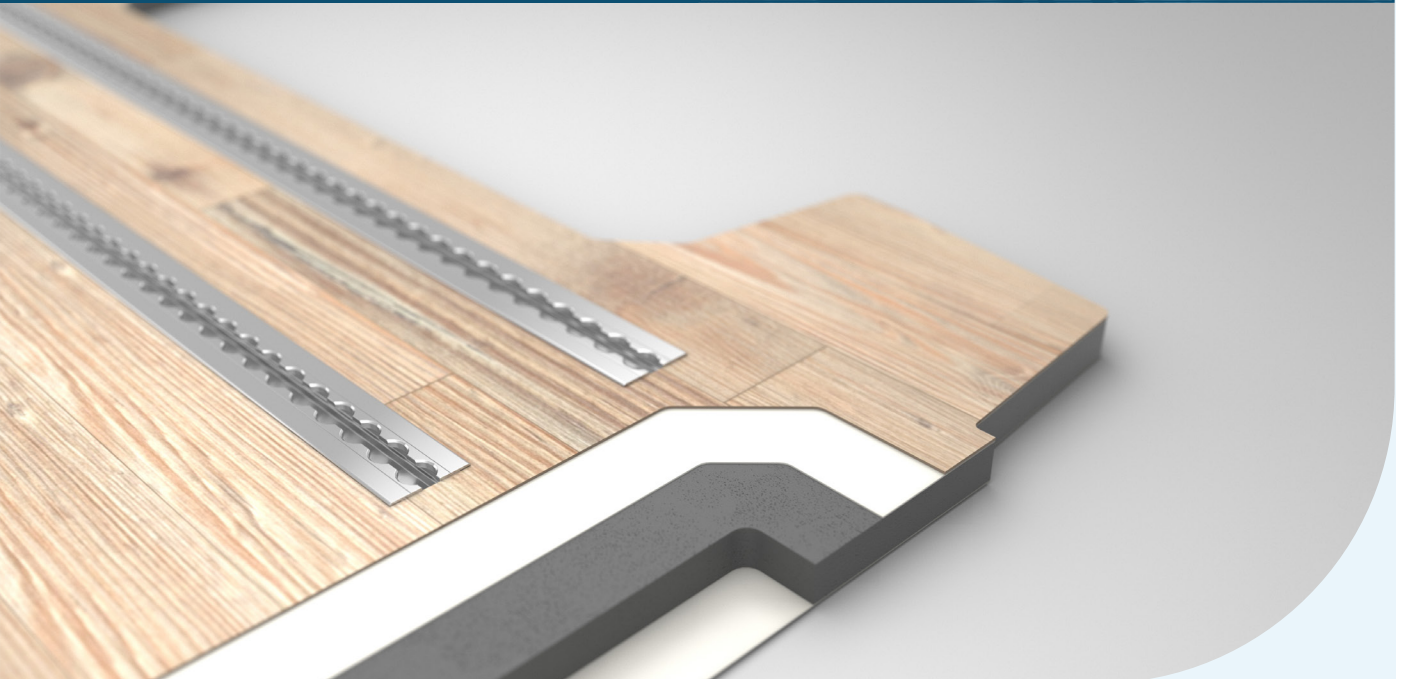
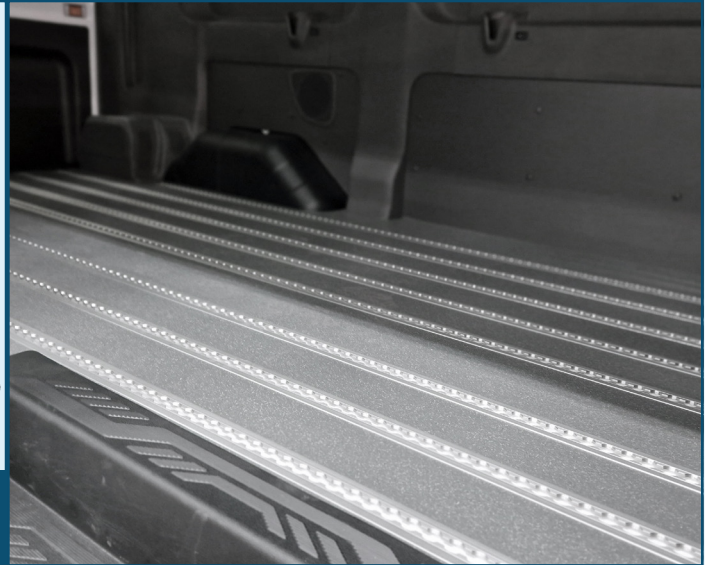

Index

1. Safety..... 4
 1.1 Intended use..... 5
 1.2 Personnel requirements.....5

2. Product description..... 6
 2.1 General description..... 6
 2.2 Orientation & placement of the Smartfloor Revolution.....7

3. Installation..... 8
 3.1 Safety information for installation..... 8
 3.2 Checklist before installation..... 8-9
 3.3 Test fit floor in vehicle..... 10
 3.4 Mark positions of the rail..... 10
 3.5 Cleaning of the Smartfloor Revolution and vehicle floor..... 11
 3.6 Install the aluminium strips (with primer & glue)..... 11-12
 3.6.1 Putting primer on the strips and vehicle floor surfaces..... 12
 3.6.2 Putting glue on the vehicle floor surfaces to install the aluminium strips..... 12
 3.6.3 Rail support.....13
 3.7 Apply Sika Primer-207 to the final remaining surfaces.....14
 3.7.1 Apply Sikaflex-268/Sikaflex-268 PowerCure.....15-16
 3.8 Placement of the Smartfloor Revolution onto the vehicle floor..... 17
 3.9 Drilling positions through vehicle floor..... 18
 3.10 Mounting of the Lock plates..... 19
 3.11 Finalizing installation process..... 20

4. Maintenance.....19
 4.1 Cleaning instructions.....19
 4.2 Cleaning methods.....19

Foreword

Dear reader,

These Installation Instructions serve to provide all information required for a correct and safe installation of the Smartfloor Revolution. The Smartfloor Revolution is designed and constructed in accordance with state-of-the-art technology and recognised safety standards.

Inspect the underside of the vehicle floor and note wiring, cross members, frames, fuel tanks and other possible obstructions before beginning installation.

This document is forbidden to be reproduced or duplicated, in full or in part, without the prior, written permission of the manufacturer.

Guarantee

Use only original spare parts, hardware or spare parts which have been approved of by the manufacturer.

If spare parts other than these are used, this can have a negative effect on the specified characteristics, the functionality and safety of the Smartfloor. Using non-original or unauthorised spare parts will render the guarantee null and void.

Contact us to order spare parts or accessories.

1. Safety

Explanation of symbols and signs

To improve understanding, the following conventions should be met for these instructions:



DANGER!

Warns of a situation of immediate danger, which will lead to severe or fatal injuries if not avoided.



WARNING!

Warns of a potentially dangerous situation, which will lead to severe or fatal injuries if not avoided.



CAUTION!

Warns of a potentially dangerous situation, which will lead to slight or minor injuries or material damage if not avoided.



ATTENTION!

Indicates a potentially dangerous situation, which can cause material damage if not avoided.



Gives a reference to important information in other sections and documents.



Contains general notes and useful information.

1. Safety

The installation company itself is responsible for adherence to the safety regulations when installing the Smartfloor Revolution. Installation is carried out at the sole risk installation company.

The manufacturer will accept no liability whatsoever for damage caused during installation of the Smartfloor Revolution.

Unless such damage is caused by grossly negligent or intentional breach of contract on the part of the manufacturer.

In addition to the information given in these installation instructions, local legislative regulations must be taken into consideration, in particular those regarding safety and accident prevention.

Documents

In addition to this manual, the following documents and additional documents are available on the Smartfloor website download section:

- The Sika Cleaner P, safety data sheet
- The Sika Primer-207, safety data sheet
- The Sikaflex-268 PowerCure, safety data sheet
- The Sikaflex-268, safety data sheet
- Specific vehicle drawing



1.1 Intended use

The Smartfloor Revolution described in this manual is only intended for vehicle floor conversion.

Intended use also requires that:

- All data in this manual is observed and understood.
- All safety instructions are observed and understood.



Incorrect installation of this product can lead to damage or even personal injury!

This product may not be used when:

- Any malformation to the product or damage have been discovered.
- Product parts are incomplete.

1.2 Personnel requirements

The Smartfloor Revolution must only be installed by Smartfloor trained and certified personnel:

- Who have read and understood these installation instructions.
- Of whom it can be expected, that they will execute the job entrusted to them in a responsible and reliable manner.
- Who have been expressly assigned by the vehicle's owner to install the Smartfloor Revolution.

2. Product description

2.1 General description

Smartfloor has designed and manufactured a new type of floor system called, the Smartfloor Revolution, which is roughly 30% lighter compared to a conventional Smartfloor.

The patented floor is produced from a composite floor-sheet, which is, together with the aluminium profiles, glued into the vehicle. Based on customer input, the floor can be manufactured in many different configurations and has a low thermal conductivity.

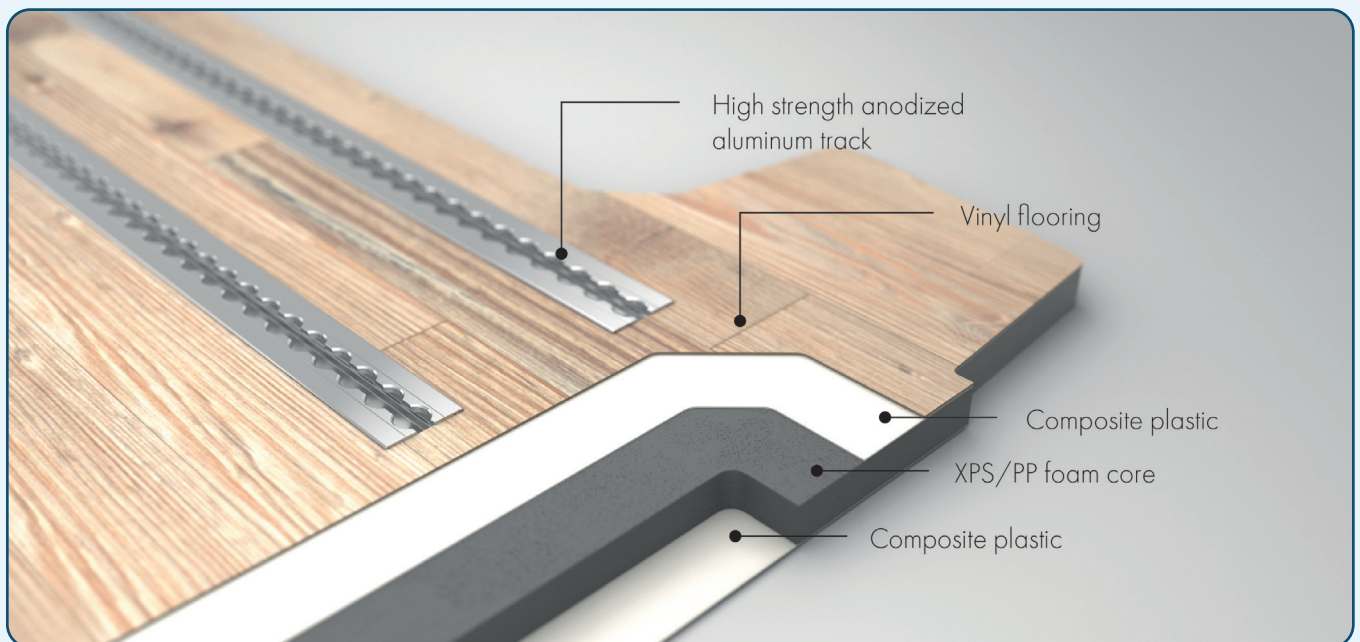

Example of a Smartfloor Revolution cut-out in layers with different types of materials.

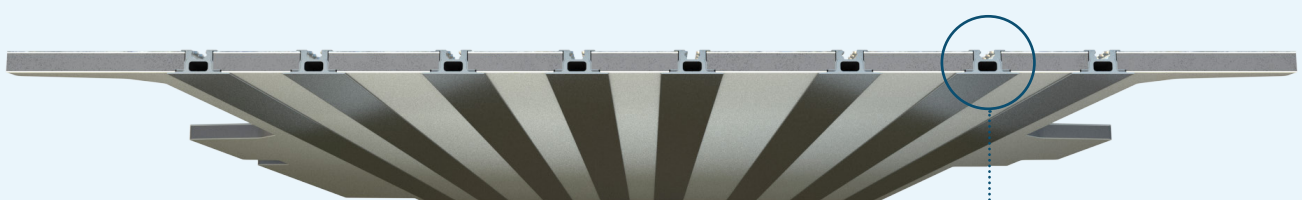

Underneath view of the Smartfloor Revolution.

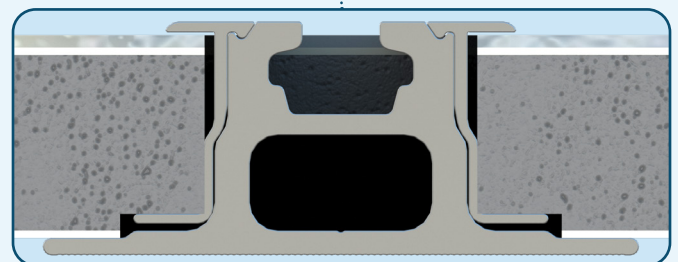

Cross-section showing the Smartfloor Revolution profile and composite floor-sheet.

2. Product description

2.2 Orientation & placement of the Smartfloor Revolution

- The Smartfloor Revolution must be installed over the entire width (A) and length of the vehicle floor (B).
- The rail of the Smartfloor Revolution must always point in the travel direction (C).

i The minimum possible rail length is 1 meter.

! It is not permitted to significantly shorten the floor length and width for reasons other than adjustments for making it fit into the vehicle! Cutting away material from the Smartfloor Revolution profiles is not allowed!

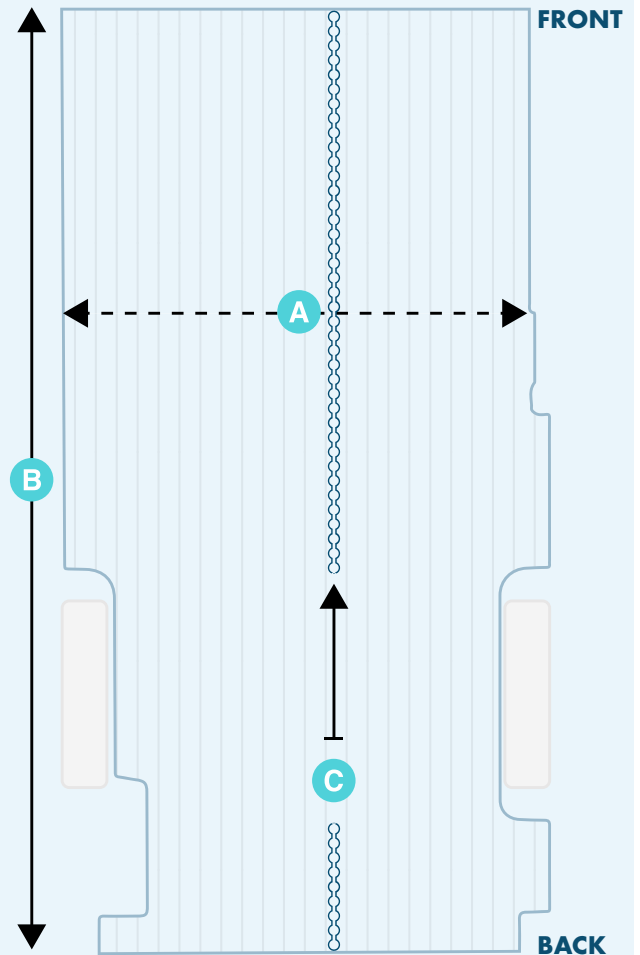

Top-view vehicle floor with Smartfloor Revolution

3. Installation

3.1 Safety information for installation



DANGER!

Danger through use of unsuitable installation materials. Unsuitable installation materials are unable to withstand the traffic forces encountered during operation of the vehicle. Multiple risks of injury for passengers can arise as a result of this. Material damage can be caused. Therefore:

- Only use the installation materials provided for installation.



DANGER!

Danger through bolts becoming loose. If bolts are not tightened correct, they can loosen during operation of the vehicle. This can result in accidents being caused. Therefore:

- If any of the vehicle's original screws are loosened or removed for installation of the Smartfloor Revolution, they must be re-tightened to the torque specified by the vehicle manufacturer.



ATTENTION!

Material damage can be caused by incorrect installation. Therefore:

- Study these Installation Instructions thoroughly before installation, so that you are familiar with the entire installation procedure.

3.2 Checklist before installation

Tools needed:

- | | |
|-----------------------------------------------------------------------|-----------------------------------------------------------|
| 1. Caulking gun (electric/air pressure, suitable for 600ml sausage) | 7. Hoist bar |
| 2. Wiping paper / cleaning cloth | 8. Knife (carpet cutter) |
| 3. Paint roller (felt) + tray | 9. Personal protective equipment (see data sheets Sika) |
| 4. Tape measure | 10. Wrench / Torque wrench |
| 5. Drill with bit size Ø 10,5mm / Ø 8,5mm | 11. Jig saw (if applicable) |
| 6. Hoist crane (preferred) | 12. Spirit level/Tri square |
| | 13. Marker |

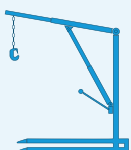

3. Installation

Installation materials:

Before starting installation, check the completeness of the supplied installation materials according to the floor drawings:

- Complete Smartfloor Revolution (with floor cover and rails)
- Sika Primer 207
- Sikaflex 268/Sikaflex 268 PowerCure
- Anti-corrosion spray
- Sika Cleaner P
- Lock Plates
- M10x40 or M8x40 ISO 4762 / DIN 912 class 8.8 or 10.9
- M10 or M8 lock nut ISO 10511 / DIN 985 class 8.8 or 10.9
- Aluminium Strip Kit, supplied for each specific vehicle

Additional materials if needed:

- M10x180 or M8x180 ISO 4762 / DIN 912 class 8.8 or 10.9
- U-profile instead of Lock Plates

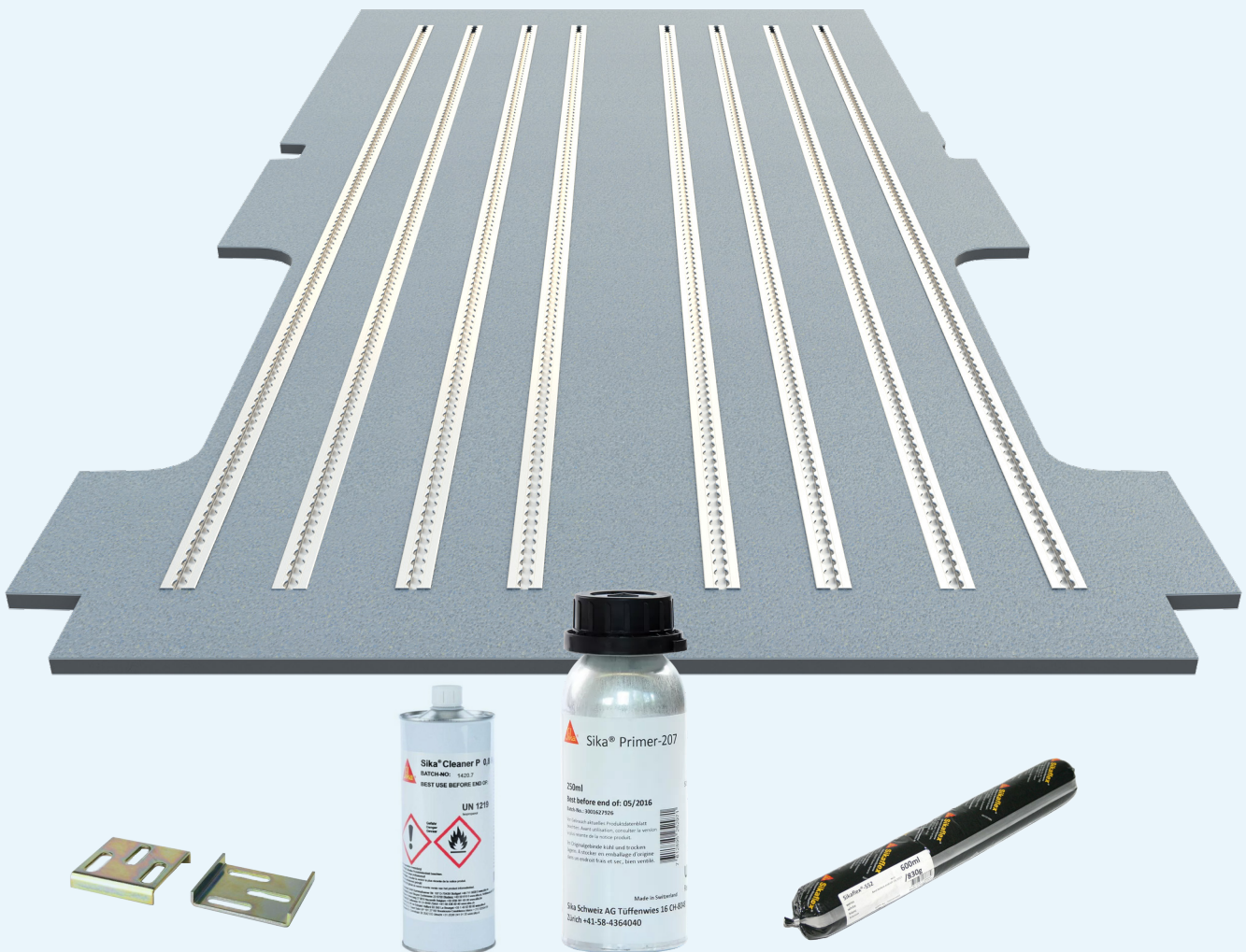

3. Installation

3.3 Test fit floor in vehicle

It is advised to test fit the floor inside the vehicle before glueing.

i This is to check if the floor will fit properly and will also help to determine where the rail locations are going to be. Please note, the contour shape of the vinyl flooring is intentionally made slightly larger than the composite under layer of the floor.

1. Check if the floor lays completely flat onto the vehicle floor.
2. Check whether the Altro vinyl flooring fits neatly along the vehicle walls. If not, cut away excessive material.
3. If the floor doesn't fit properly cut away excessive material (complete floor thickness) with a jig saw.

! Only cut away material from the composite floor material!
Cutting away material from the Smartfloor Revolution profiles is not allowed!

3.4 Mark positions of the rail

With the Smartfloor Revolution still in the vehicle;

- Mark the centre line positions of each rail at the front and back of the vehicle floor and make sure that the marks are outside the area where the Smartfloor Revolution eventually will be installed.

! It is important that each rail is thoroughly glued to the vehicle floor. Therefore, it is necessary to mark the position of each rail.

i By marking the centre line of the rail it will be easier to determine the positioning of the aluminium strips (see chapter 3.6).

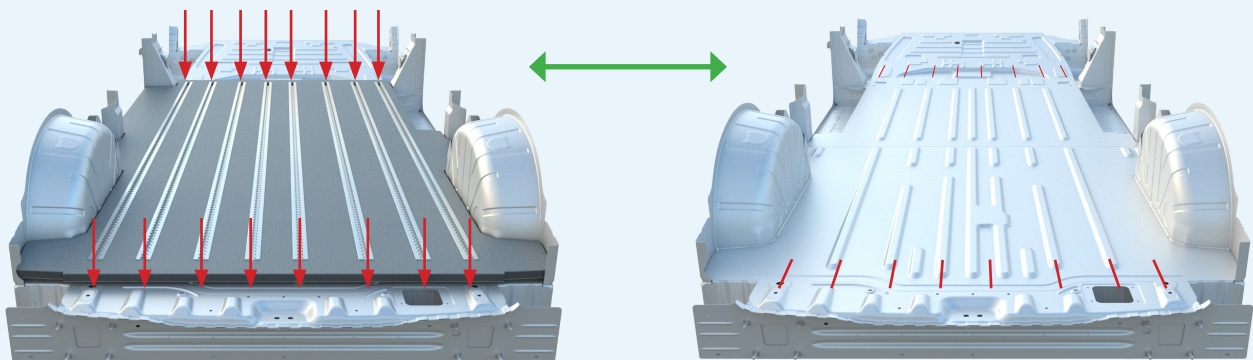

Preview of position of each rail

Red marker lines for the position of each rail

3. Installation

3.5 Cleaning of the Smartfloor Revolution and vehicle floor

The underside surface of the Smartfloor Revolution, the aluminium strips and the vehicle floor should be clean, dry and free of grease, oil and dust prior to the next step.

For degreasing use Sika Cleaner P and apply with a wiping paper or cleaning cloth.

1. Position the Smartfloor Revolution up side down.
2. Make sure that the surface of the Smartfloor Revolution, both sides of the aluminium strips and of the vehicle floor are clean.



For all product information about the Sika products please read the data sheet and safety data sheet, which can be found on the Smartfloor website.



Do not walk over the uncovered floor after cleaning! Cover the vehicle floor with a clean material piece before entering. It is allowed to place a clean piece of cardboard onto the vehicle floor surface to stand on during the installation process.

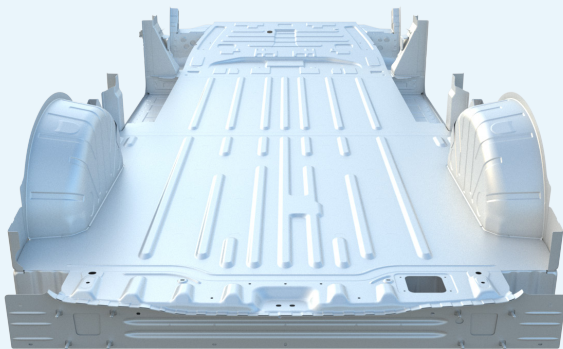

Vehicle floor surface

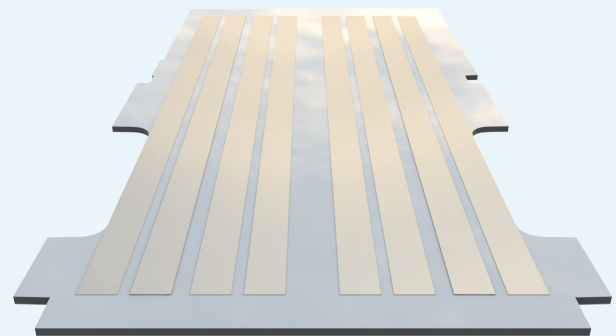

Up side down view of the Smartfloor Revolution

3.6 Install the aluminium strips (with primer & glue)

See below an example of the red positions of where the strips are going to be:

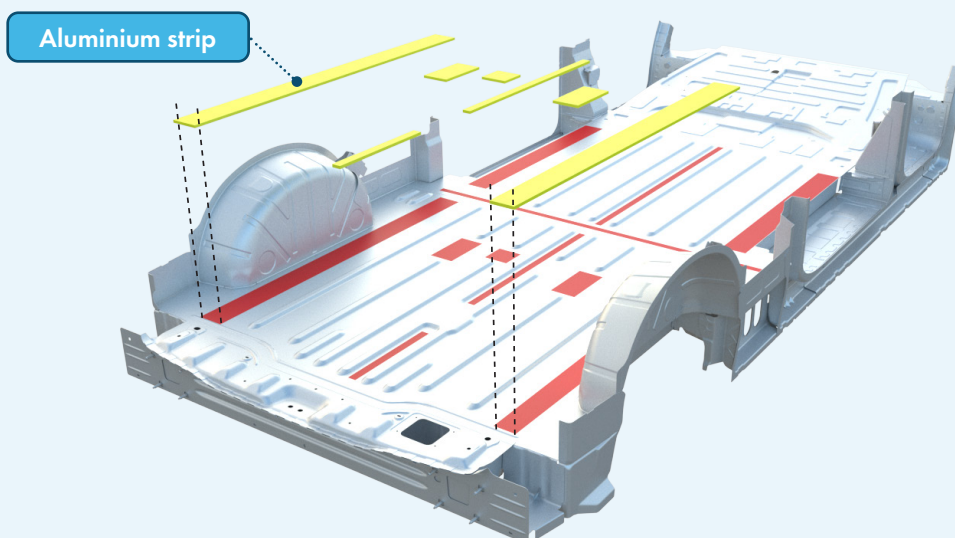

Vehicle floor with position spots and strips

3. Installation

3.6.1 Putting primer on the strips and vehicle floor surfaces

Follow these steps to install the strips:

1. Apply the primer on the **red** areas where the aluminium strips will be installed, see example in the picture on the right **(A)**.
2. Make sure that you let the primer dry for at least 10min before proceeding with the next step.



The positions of the strips are determined by the positions of the rails and by the floor bumps of the vehicle floor. See chapter 3.6.3 for instructions were to position the aluminium strips.

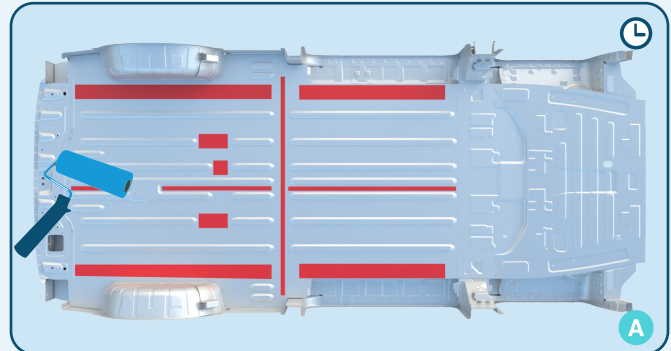

Top-view vehicle floor with indicated positions for the strips

3.6.2 Putting glue on the vehicle floor surfaces to install the aluminium strips

3. Apply glue onto the surfaces with the applied primer **(B)**.
4. Compare the shape of the strips with the location shapes and determine which piece corresponds to which area.
5. Place and align each aluminium strip piece on top of the applied glue, with the primed surface facing the glue **(C)**.
6. Press the strips down until they have the same height as the upper surfaces of the vehicle floor with use of a straight tool.



It is very important that each Smartfloor Revolution rail is thoroughly supported from underneath with either the vehicle floor or aluminium strip. See next page for more information and further instructions.

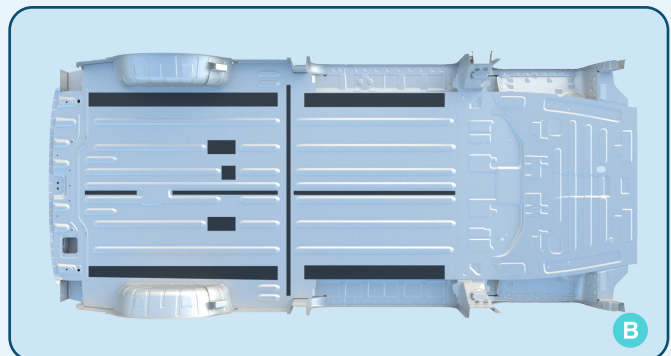

Top-view treated floor areas with primer

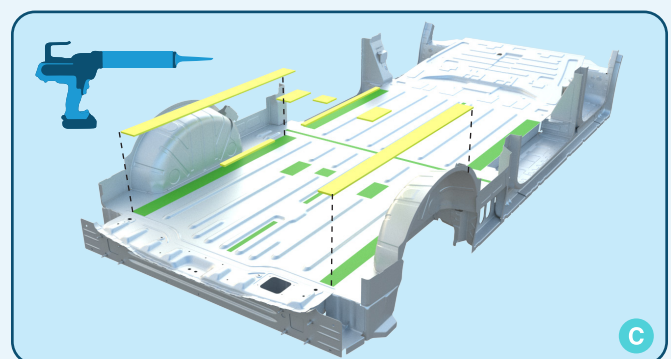

Vehicle floor with green position applied with glue

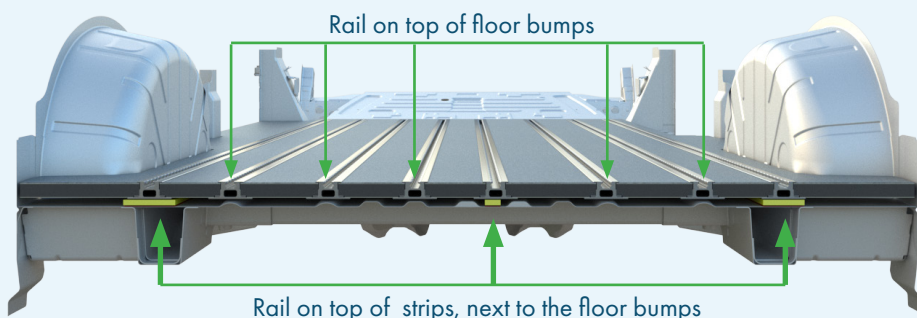

Legend:

- Primer positions
- Treated Surface with primer
- Aluminium Strips
- Glue applied positions

3. Installation

3.6.3 Rail support

See below the first three appropriate ways illustrated of were to position the aluminium strips and how to apply the glue. The last illustration is an example of how it is done incorrect!

1. With rail and glued strip into the vehicle floor gap. ✓
2. With rail centred onto the vehicle floor bump. ✓
3. With both rail side edges fully covering the vehicle floor bumps. ✓
4. **WRONG EXAMPLE:** With rail in between vehicle floor bumps. The rail is not touching the glue underneath (gap to big, placement of a strip is needed). ✗

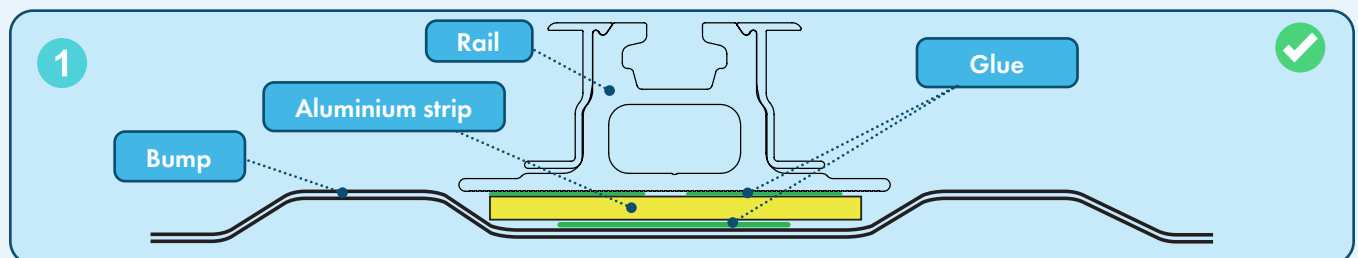

Cross-section with rail and glued strip into the vehicle floor gap.

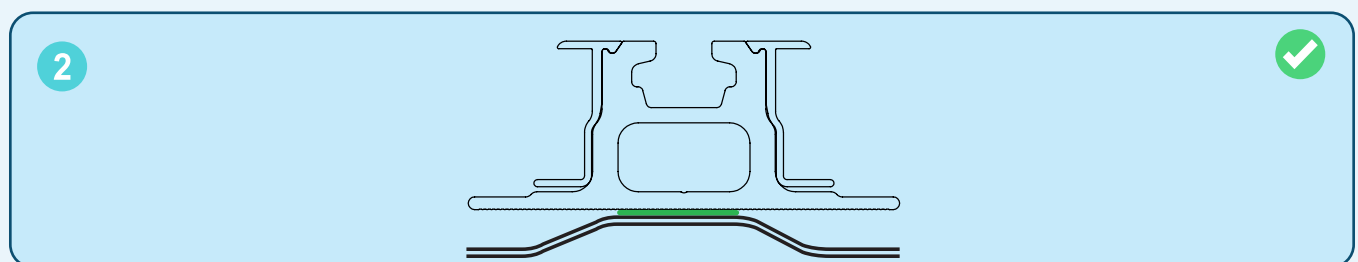

Cross-section with rail centred onto the vehicle floor bump.

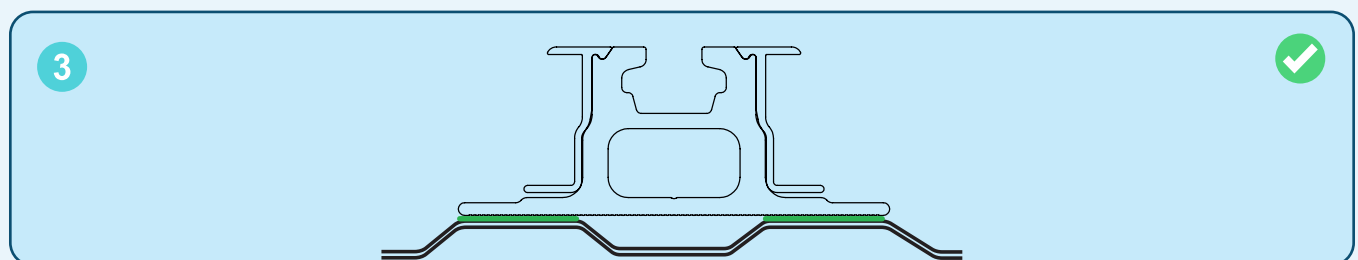

Cross-section with both rail side edges fully covering the vehicle floor bumps.

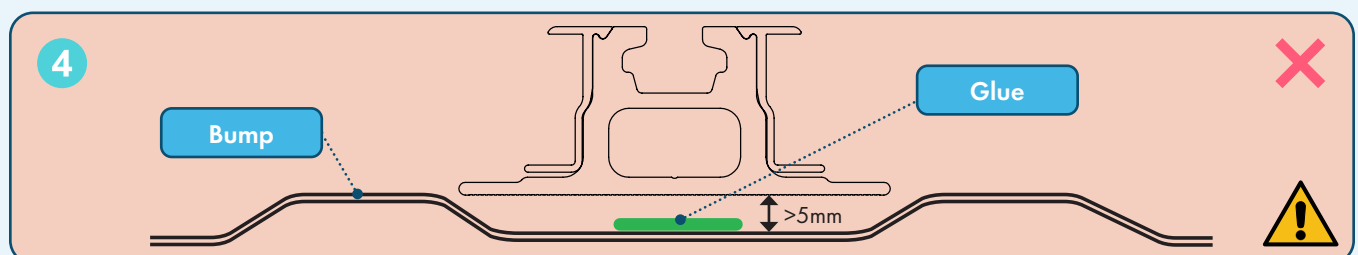

Cross-section with rail in between vehicle floor bumps.
The rail is not touching the glue underneath (gap to big, placement of strip is needed).

3. Installation

3.7 Apply Sika Primer-207 to the final remaining surfaces

The easiest way is to primer the complete vehicle floor surface equal to the dimensions of the Smartfloor Revolution. Primer-207 should be applied to all surfaces where the glue will be applied.

1. Apply primer with a paint roller to the surfaces **(A)** where the glue will be applied.
2. Apply primer to the complete bottom surface of the Smartfloor Revolution, when placed up side down **(B)**.
3. Make sure that you let the primer dry for at least 10min before proceeding with the next step. ⌚



For all product information about the Sika products please read the data sheet and safety data sheet, which can be found on our Smartfloor website.



Do not walk over the floor without covering the surface after applying primer!
Cover the vehicle floor with a clean material piece before entering.
It is allowed to place a clean piece of cardboard onto the vehicle floor surface to stand on during the installation process.

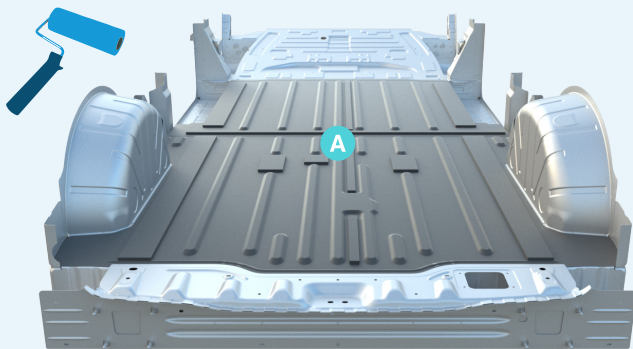

Applied primer to the whole vehicle floor

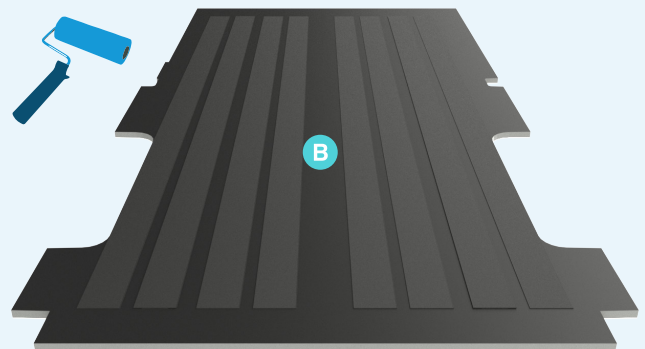

Applied primer to the Smartfloor Revolution

3. Installation

3.7.1 Apply Sikaflex-268/Sikaflex-268 PowerCure

The gluing positions applied onto the vehicle floor is different for each brand and type of vehicle.

i The amount of glue needed is 1200ml/m².

How to determine glue positions:

1. Determine where to apply the glue according to your specified vehicle drawing by looking at the green areas.
2. Also use your own marked positions on the vehicle floor from [step 3.4 on page 10](#) as your guiding line and indication for applying glue strokes.

See example of marked positions and technical drawing below:



Red marker lines for the position of each rail

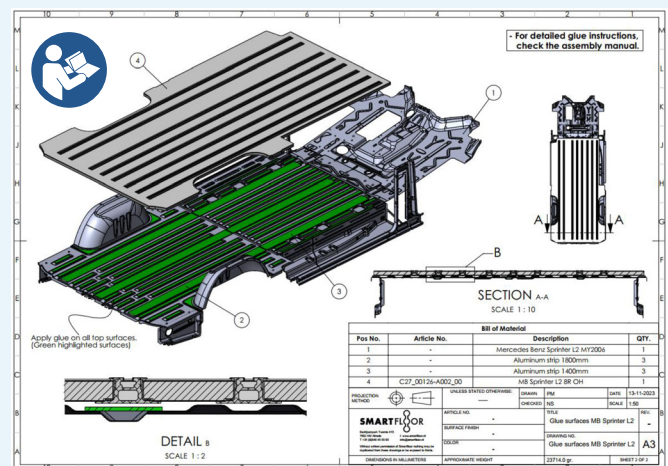

Example of technical drawing for gluing instructions

3. Installation

How to glue

First read and understand the following steps before you start!

1. With a caulking gun apply the Sikaflex 268 or Sikaflex 268 Powercure onto the vehicle floor surface.
2. Start from the back to the front of the vehicle.
3. Clots: Apply glue clots in between the floor bumps where there are no Revolution profiles positioned (only the composite floor sheet).
4. Single stroke: Apply single glue strokes on top of all the highest floor surfaces like the floor bumps and installed strips, where there are no Revolution profiles positioned (only the composite floor sheet).
5. 2x stroke: Apply two nearby glue strokes where the Revolution profiles will be positioned (highest floor surfaces). These positions are marked in step 3.4.



Sikaflex 268 / Sika 268 PowerCure applied to the vehicle floor.

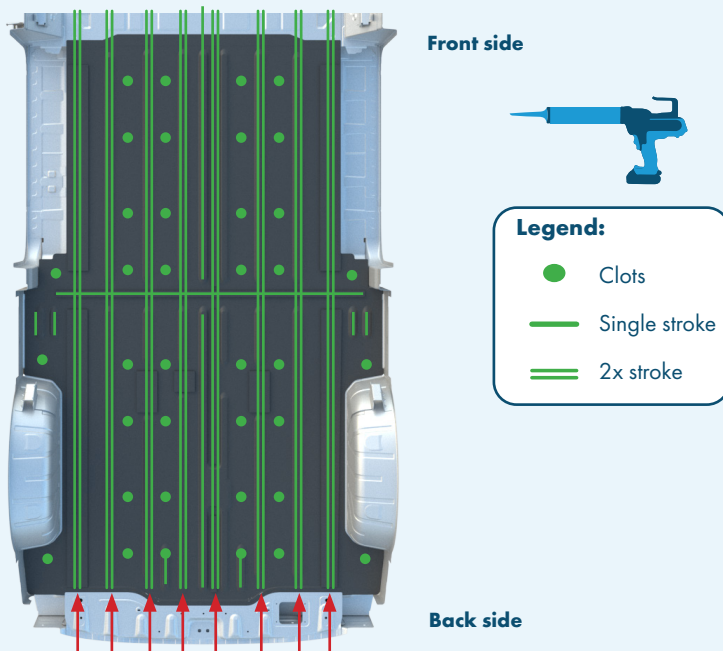

Example of glue strokes with the rail positions in top-view

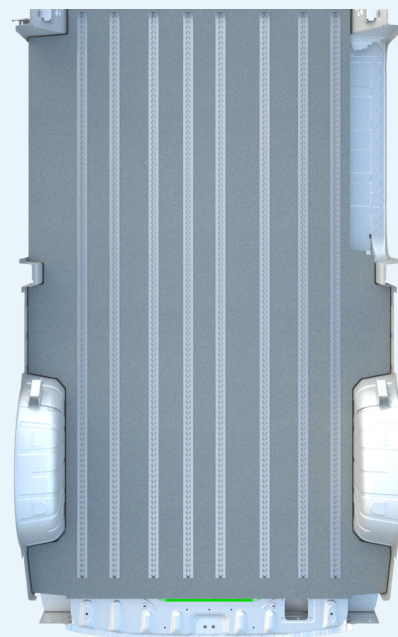

Placed floor in top-view to compare with left side figure.

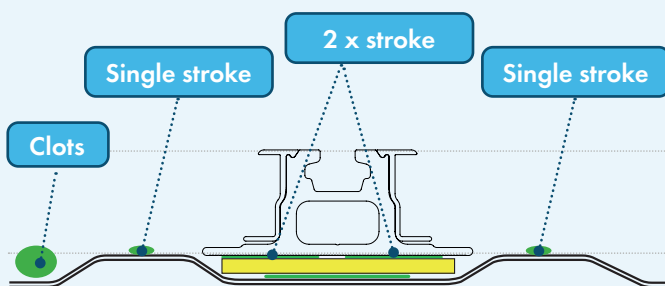

Examples of applied glue: clots, single stroke, 2x stroke.



It is really important that each rail is glued to the vehicle floor or aluminium strip properly (this means with 2x glue strokes along the length of the rail)



It is also important that the floor is placed on the glue within 40min after applying the first glue. ⌚ This is due to the glue's open time of 40min and a skin time of 60min.



For all product information about the Sika products please read the data sheet and safety data sheet, which can be found on the Smartfloor website.

3. Installation

3.8 Placement of the Smartfloor Revolution onto the vehicle floor



The installation of the Smartfloor should be done by at least two persons.



1. Attach hoist bar to the floor when using a hoist crane (A).

Use a minimum of 2 4-Stud fittings to attach the hoist profile to the SF Revo. Make sure that the hoist profile position is in the centre of the Smartfloor Revolution.

2. The hoist profile will keep the Smartfloor Revolution flat during lifting.
3. Avoid any deformation of the Smartfloor Revolution during placement.
4. Position the floor diagonal and move the Smartfloor Revolution into the vehicle (B).
5. Lower the Smartfloor Revolution until the floor hovers horizontally above the glue.
6. Check and align centre of the rails with the marked positions (see step 3.4 on page 10)
7. Lower the floor onto the glue and check position again and correct if necessary.



Don't force the Smartfloor in its final position!
Don't try to hoist the Smartfloor into the air after laying it onto the glue!

8. Walk over the whole floor surface to put extra pressure for optimal glue connection.
9. Check if the Smartfloor lays flat with a straight edge.
10. Check with the naked eye at the back side and side entrance if the floor is thoroughly touching the glue.

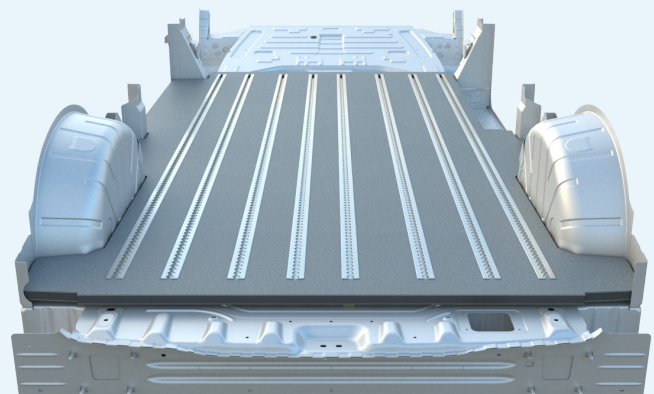

Smartfloor Revolution in its final position (example)



Hoist bar with 4-stud fitting



Move the Smartfloor Revolution into the vehicle

3. Installation

3.9 Drilling positions through vehicle floor

! Before proceeding, it is advisable to wait at least 12 hours in-between the previous step 3.8 and the next following steps. **⌚**

Each Revolution Rail must be thoroughly secured to the vehicle with a lock plate or U-profile at the end of each rail. This also applies to rails terminating in front of a wheel arch. See position **(A)** and **(B)** at the figure on the right. Lock plate offset distance from the backside is between 50–250 mm (1.96"-9.84") or after the first next possible position.

1. Check underneath the vehicle at the bottom for the most suitable position to drill without any obstacles.
2. Start with making a choice between bit size drill Ø8,5mm or Ø10,5mm, when using M8 or M10 bolts for mounting.
3. Drill completely through the Smartfloor Revolution and vehicle floor at the rail position with your determined bit size drill.
4. Drill at the same position from previous step with bit size drill Ø18 through the first top layer of the rail until position **(C)**.

This is for clearing the way for the bolt head which will be installed.

5. Repeat step 2 and 3 for all the rear ends on the rail profiles.
6. After drilling use anti-corrosion spray on the vehicle floor to protect against corrosion.

These drilled holes will be the lock plate mounting positions.

See preview illustration on the right side, showing the bolt position for lock plate mounting:

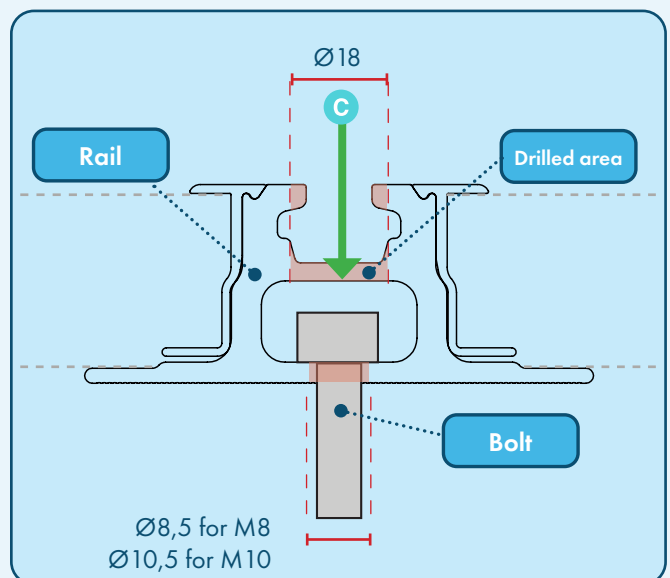
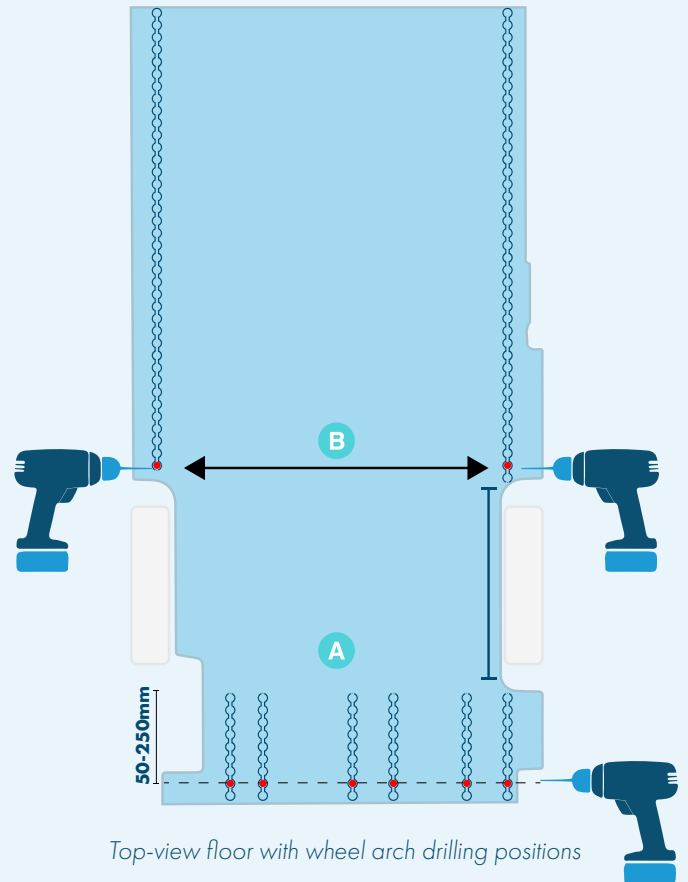

Cross-section showing the Revolution Rail with bolt placement

3. Installation

3.10 Mounting the Lock plates

For securing the Smartfloor Revolution to the vehicle, use the supplied Lock Plates or U-profile and M10x40 or M8x40 bolts.

i When drilling through the vehicle chassis members M10x180 or M8x180 bolts are needed.

! The bolts with lock nuts need to be tightened, until the lock plates lay flat underneath against the vehicle floor. Also the Smartfloor should stay level and straight during tightening.

Lock plate orientation

It is preferred to position the lock plates in the same direction that the vehicle is traveling. The other way is to mount the lock plate with 90 degree rotation from the travel direction. It is not allowed to mount the lock plate upside down!

! Do not place and mount the lock plate upside down!

See descriptions below and the figures on the right side with 3 different lock plate orientations:

- 1. Most preferred orientation in travel direction.
- 2. In a 90 degree angle rotation.
- 3. **WRONG EXAMPLE: upside down placement**



View from underneath vehicle with lock plates

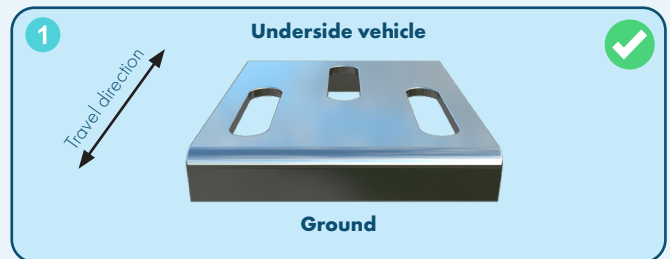

View of the lock plate with example of the correct placement in travel direction

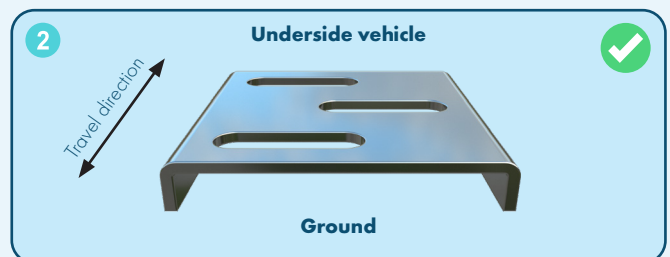

View of the lock plate with example of the correct placement with 90 degree rotation

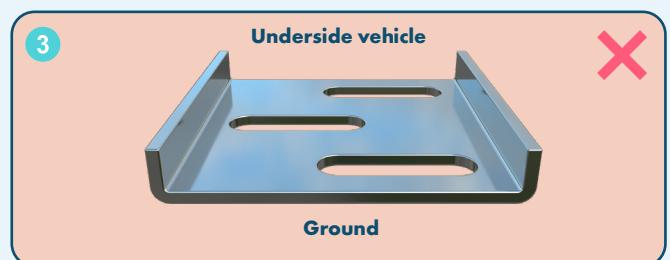

View of the lock plate with example of the incorrect placement upside down

3. Installation

3.11 Finalizing installation process

Applying silicone (optional)

For the finishing touch after the Smartfloor Revolution is installed, apply an even amount of silicone along the vehicle side walls.

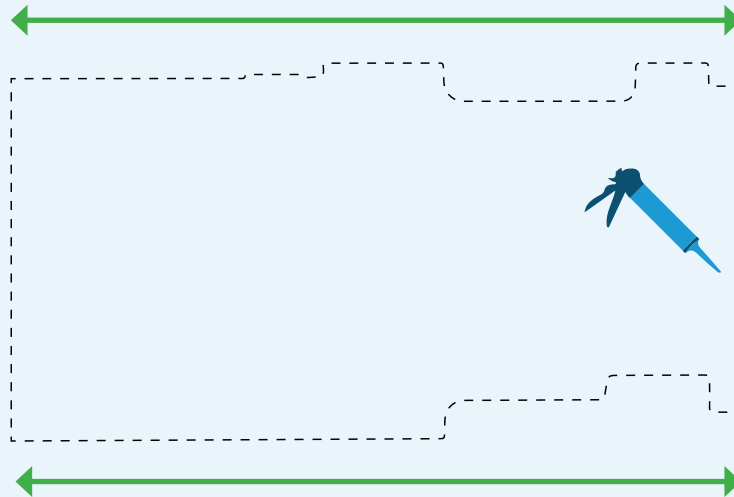

Floor End Cover Strip (optional)

For the finishing touch mount a cover strip at the backside of the Smartfloor Revolution to cover the floor.



Installation complete!

Contact and support

For service and technical support please contact us:

Smartfloor B.V.
Bedrijvenpark Twente 415
7602 KM Almelo
The Netherlands

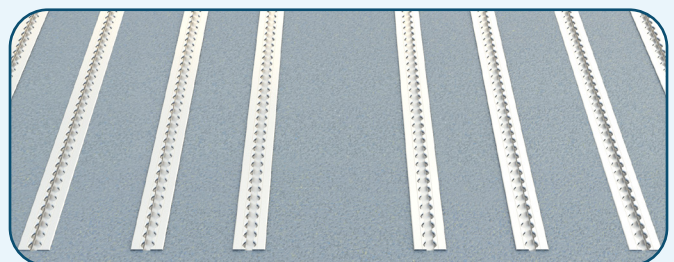

4. Maintenance

4.1 Cleaning instructions

1. Check airline rail and anchorages for cleanliness.
2. Remove any debris or obstruction.
3. Perform a dry cleaning method first (see next section 4.2).
4. Perform a wet cleaning if necessary and let the floor dry before use (see next section 4.2).

The following cleaning products are not allowed to use when cleaning the Smartfloor:

- Harsh detergents
- Oily soaps
- Concentrated bleach products



*Do not use harsh chemicals!
This can lead to damage of the floor and rails.*



*Do not use excessive water or a water hose (garden hose) when cleaning!
The water can leak underneath the floor and can cause the floor to loosen.*

4.2 Cleaning methods

Dry cleaning method:

1. Vacuum cleaner.
2. Compressed air.

Wet cleaning method with a mild detergent:

1. Moist mop or sweeper.
2. Damp cloth with tepid water.